

A world  
of sensations

Tempo

Hot drinks



**AZKOYEN**  
*Vending for life*

# A World of Sensations.

We use our knowledge to achieve a coffee with its full flavour.

Tempo is a state of the art automatic distributor with a highly attractive cutting edge design which adapts to any type of establishment.

Tempo's versatility facilitates the preparation of a wide variety of excellent espresso and instant coffees with body, aroma as well as infusions and other hot drinks that shall delight your customers.



## MAXIMUM QUALITY

- Constant and homogeneous aspect and quality.
- The AZKOYEN coffee group guarantees coffee with top quality cream, body and aroma.
- A wide range of drinks.

## ATTRACTIVE DESIGN

- A highly attractive cutting edge design which adapts to any type of establishment.
- Clear and attractive selection panel.
- LED lit preselections and selections.
- Chrome plated back-lit direct selection keypad buttons

## EASY TO CLEAN

- Modular components which can be easily extracted.
- Materials specifically for maximum hygiene.
- Product independent mixture.
- Selfwashing programme.

# Tempo

Hot drinks

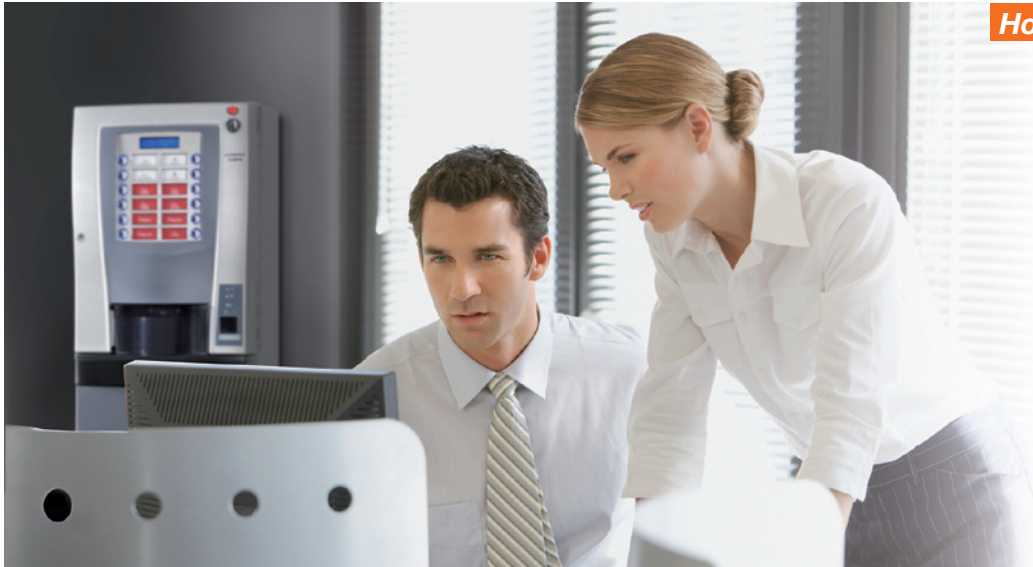

## EASY INSTALLATION AND MAINTENANCE

- Modular construction.
- Direct access to key parts.
- Fast and simple configuration and programming of the machine.
- Display that shows information regarding machine errors in a clear and simple manner (selfdiagnosis service and repair suggestions).
- Accounts data can be extracted via RS-232. Optional: Bluetooth – EVA DTS.

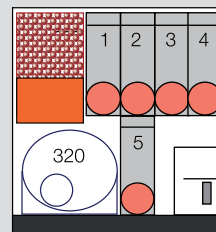

Tempo L **espresso**

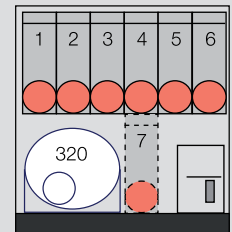

Tempo L **instant**

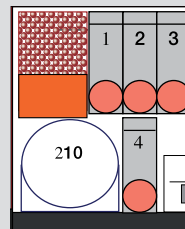

Tempo M **espresso**

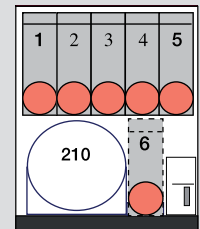

Tempo M **instant**



Tempo M **instant**



Tempo L **espresso**

**AZKOYEN**  
*Vending for life*

# Tempo

Hot drinks

Accessories	Tempo M		Tempo L	
	espresso	instant	espresso	instant
105 mm stirrer kit	•	•	•	•
73 mm diameter cup extractor	•	•	•	•
Stand-alone kit	•	•	•	•
Base unit	•	•	•	•
Coin mechanism prepared based unit	•	•		
Sugar & Stirrer kit situated in door		•		•
Note reader kit	•	•	•	•
Validator kit	•	•		
Kit for connection to snacks Brisa machines			•	•
Double canisters	•	•	•	•

Capacity	Tempo M		Tempo L	
	espresso	instant	espresso	instant
Cup capacity (150 cm <sup>3</sup> )	210	210	320	320
Selections	8	8	8	8
Preselections	4	4	4	4
N° of coffee granule canisters	1	-	1	-
Coffee granule capacity (l)	3,1	-	5,5	-
Coffee granule capacity (kg)	1,1	-	1,9	-
N° of soluble canisters	4	5	5	6
Soluble canister capacity (l)	1,6	1,6	3	3
Soluble coffee product (kg)	0,4	0,4	0,8	0,8
Milk product (kg)	0,6	0,6	1,1	1,1
Chocolate product (kg)	0,8	0,8	1,5	1,5
Tea product (kg)	1,0	1,0	2,0	2,0
Sugar product (kg)	1,4	1,4	2,6	2,6
Boiler volume (ml)	700	700	700	700

Technical characteristics	Tempo M		Tempo L	
	espresso	instant	espresso	instant
Height (mm)	650	650	740	740
Width (mm)	405	405	480	480
Depth (mm)	570	570	560	560
Base unit height (mm)	870	870	880	880
Weight (kg)	49	44	60	60
Base unit weight (kg)	16	16	19	19
Voltage (V)	230V	230V	230V	230V
Power (W)	1.800	1.800	1.800	1.800
EXE / MDB protocol	•	•	•	•

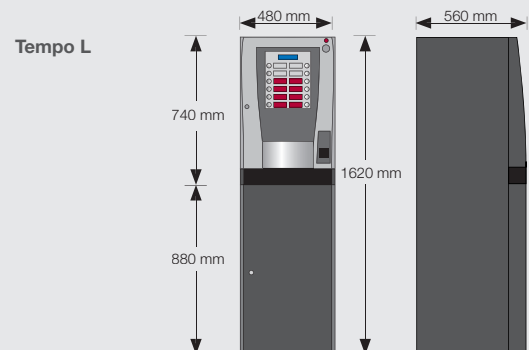
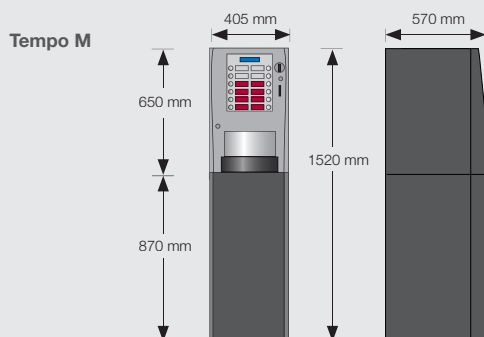

#### AZKOYEN Industrial, S.A.

Central - Spain  
Avda. San Silvestre, s/n  
31350 PERALTA (Navarra)  
Tel.: 948 709 709\*  
Fax: 948 709 708

#### AZKOYEN France S.A.R.L

France  
7 Allée de Londres  
Le Madras Bat C2  
91140 VILLEJUST  
Tel.: 01 69 75 42 10  
Fax: 01 69 75 42 11

#### AZKOYEN U.K. Ltd.

U.K.  
Suite I, Unit 19 Fyfield  
Business & Research Park  
Fyfield Road, Ongar  
Essex CM5 OGN  
Tel.: 01277- 369 799  
Fax: 01277- 369 715

#### AZKOYEN Deutschland GmbH

Deutschland  
Am Turm 15  
53721 Siegburg  
Tel.: 02241- 595 70  
Fax 02241- 595 790